

## SCD545UH

### ● FEATURES

- \* Halogen-free type
- \* Compliance to RoHS product
- \* Lead less chip form, no lead damage
- \* Low power loss, High efficiency
- \* High current capability, low VF
- \* Plastic package has Underwriters Laboratory Flammability Classification 94V-0

### ● APPLICATION

- \* Switching mode power supply applications
- \* Portable equipment battery applications
- \* High frequency rectification
- \* DC / DC Converter
- \* Telecommunication

### ● MECHANICAL DATA

**Case :** Packed with FRP substrate and epoxy underfilled  
**Terminals :** Pure Tin plated (Lead-Free),  
solderable per MIL-STD-750, Method 2026.  
**Polarity :** Laser Cathode band marking  
**Weight :** 0.02 gram

### ● PACKING

- \* 3,000 pieces per 7" (178mm ± 2mm) reel
- \* 4 reels per box
- \* 6 boxes per carton

### ● OUTLINE DIMENSIONS

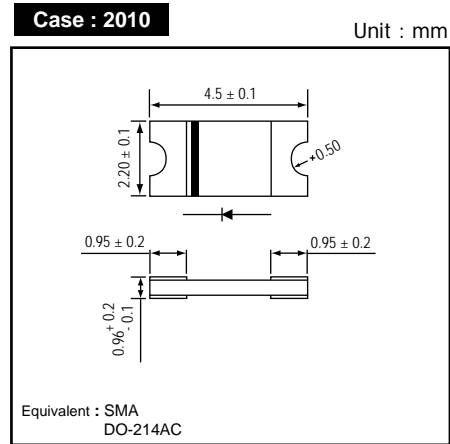

### ● MARKING

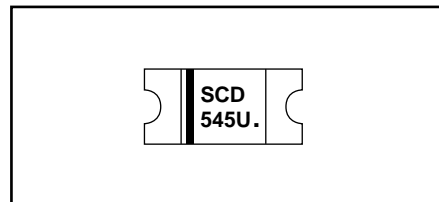

### Absolute Maximum Ratings (Ta = 25 °C)

ITEM	Symbol	Conditions	Rating	Unit
Repetitive peak reverse voltage	VRRM		45	V
Average forward current	IF(AV)	Tc = 83 °C	5	A
Peak forward surge current	IFSM	8.3ms single half sine-wave	80	A
Operating junction and storage temperature range	Tj, TSTG		-55 to +150	°C

### Electrical characteristics (Ta = 25 °C)

ITEM	Symbol	Conditions	Min.	Typ.	Max.	Unit
Forward voltage (NOTE 1)	VF	IF = 5.0A	-	0.49	0.54	V
Repetitive peak reverse current	IRRM	VR = Max. VRRM , Ta = 25 °C	-	0.05	0.20	mA
Junction capacitance	Cj	VR = 4V, f = 1.0 MHz	-	120	-	pF
Thermal resistance	Rth(JA)	Junction to ambient (NOTE 2)	-	102	-	°C/W
	Rth(JC)	Junction to case (NOTE 2)	-	18	-	°C/W

NOTES : (1) Pulse test width PW=300usec , 1% duty cycle.  
(2) Mounted on P.C. board with 0.2 x 0.2"(5.0 x5.0mm) copper pad areas.

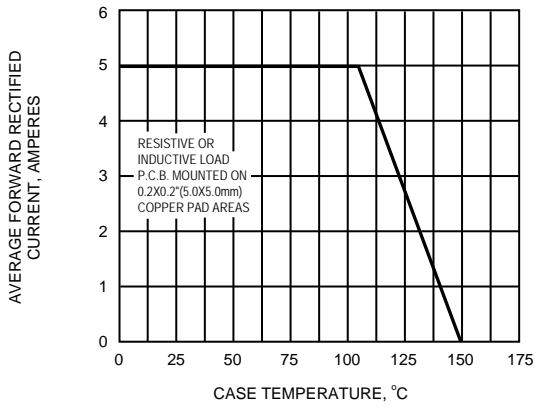
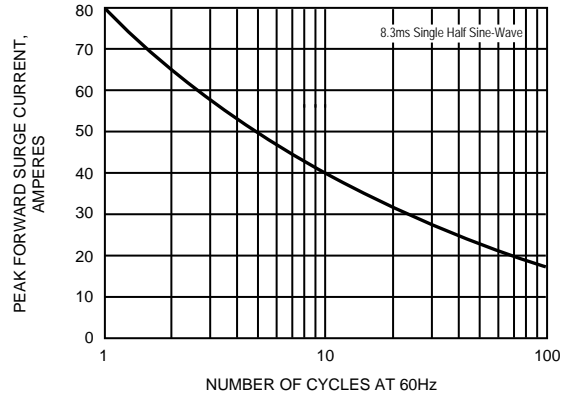
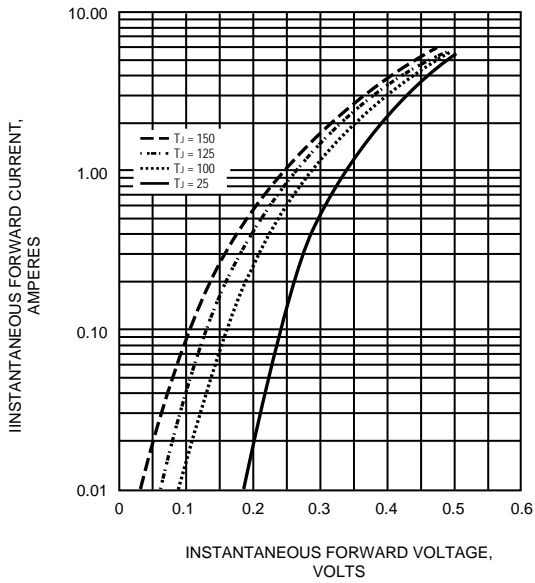
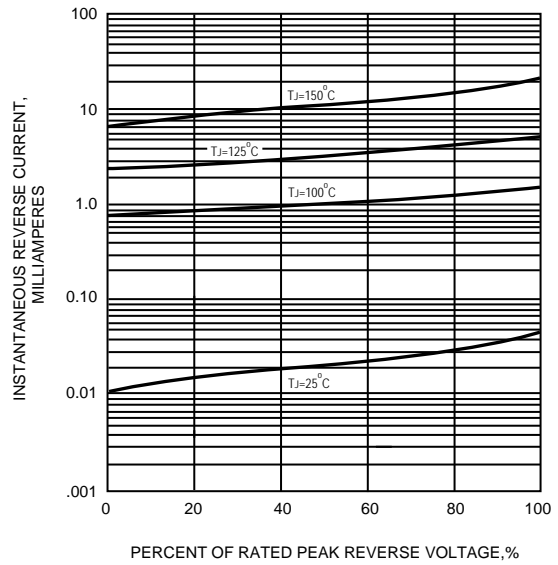
**FIG.1 - FORWARD CURRENT DERATING CURVE**

**FIG.2 - MAXIMUM NON-REPETITIVE PEAK FORWARD SURGE CURRENT**

**FIG.3 - TYPICAL INSTANTANEOUS FORWARD CHARACTERISTICS**

**FIG.4 - TYPICAL REVERSE CHARACTERISTICS**

**FIG.5 - TYPICAL JUNCTION CAPACITANCE**
